



## TECHNICAL SPECIFICATION SHEET FOOD WASTE DISPOSERS

The most convenient way to dispose of food waste in your kitchen, including chicken bones, vegetable and fruit peelings and much more. Food waste disposers provide a safe and environmentally alternative to transporting food waste to landfills.

All disposers are compliant with the EC Directive regards RoHS.  
CB Certificate Approval N° - NO75966  
Issued by



**MODEL FWD 380**

Dimensions (mm.)

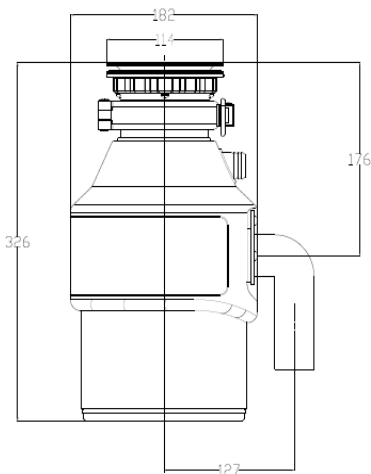

Specifications		
Type of feed	Continuous	
Motor type	AC Induction 1PH	
HP - Watt	1/2 – 370W	1/2 – 410W
Volts	220-240	110-130
Hz	50	60
RPM	1400	1700
AMP (avg. load)	3A	5A
Motor protection	Manual reset overload	
Bearings	Permanently lubricated	
Sink Flange	Nylon + Fibreglass	
Sink Stopper	Nylon	
Splash Guard	Natural rubber	
Grind Ring	Stainless Steel	
Swivel Impellers	SUS	
Turntable	Stainless Steel	
Hopper	PA+GF	
Drain Housing	PE	
Grind Chamber Capacity	1200 ml.	
Sound Shell	PE	
Dishwasher Drain Connection	Yes	
Drain Connection	Ø 40 mm.	
Disposer weight	6Kg	
Power cord attached	Yes	
Life Span	10 years	
<b>Fitted with a time saving snap-on hinged clamp system for an exclusive and economical installation</b>		

Assembly drawing

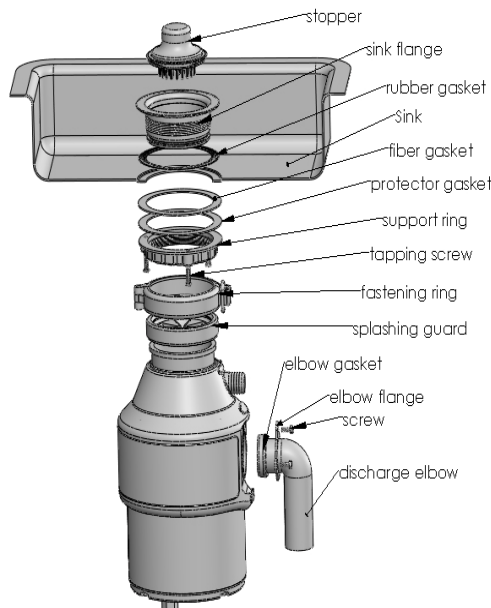

**MODEL FWD 380**  
Air switch system built in