

TECHNICAL SPECIFICATION SHEET



FOOD WASTE DISPOSERS

The most convenient way to dispose of food waste in your kitchen, including chicken bones, vegetable and fruit peelings and much more.

Food waste disposers provide a safe and environmentally alternative to transporting food waste to landfills.

All disposers are compliant with the EC Directive regards RoHS.

CB Certificate Approval

N° - NO75982

Issued by



NEW MODEL FWD 600 - V TYPE

Dimensions (mm.)

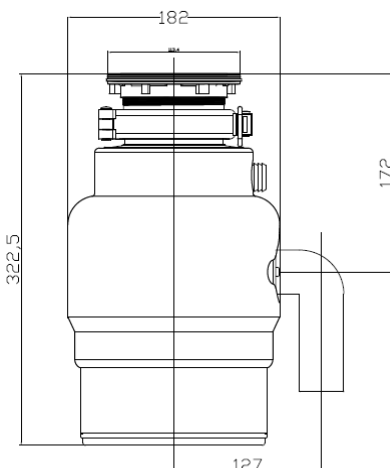

Specifications		
Type of feed	Continuous	
Motor type	AC Induction	
HP - Watt	3/4 – 600	1/2-370
Volts	220-240	220-240
Hz	50	50
RPM	1410	1375
AMP (avg. load)	4.7A	3.4A
Motor protection	Manual reset overload	
Bearings	Permanently lubricated	
Sink Flange	SS AISI 304+Zinc alloy	
Sink Stopper	Stainless Steel	
Splash Guard	Natural rubber	
Grind Ring	SS AISI 430	
Swivel Impellers	SS AISI 202	
Turntable	SS AISI 430	
Second Turntable	SS AISI 430	
Hopper	PA66+GF25%	
Drain Housing	ABS	
Grind Chamber Capacity	1200ml	
Sound Shell	PE	
Dishwasher Drain Connection	Yes	
Drain Connection	Ø 40 mm.	
Disposer weight	8,3 kg.	8,1 kg.
Power cord attached	Yes	
Life Span	10 years	
Fitted with a time saving snap-on hinged clamp system for an exclusive and economical installation		

Assembly drawing

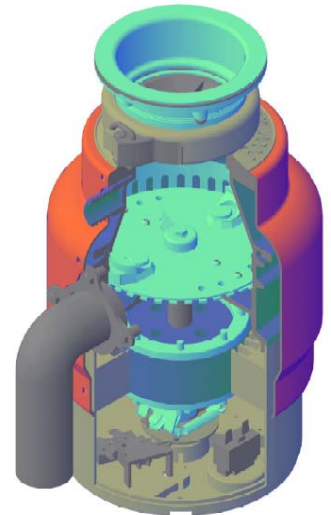
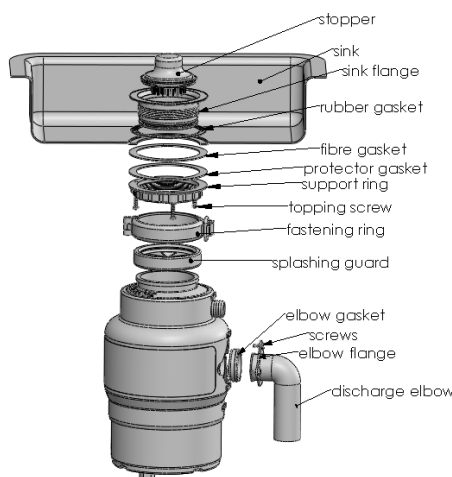

NEW MODEL FWD 600 - V TYPE

Air switch system built in