

THE DEHYDRA FOOD WASTE DEWATER COMPACT STATION – DEHYDRA SC1-

The machine is a de-watering solution to manage food waste in commercial kitchens with the following targets:

- To get reductions in weight, volume and fermentability of food waste. While the watery component goes into the sewage system, the solid component (food waste), drastically reduced in weight (about 50%) volume (about 80%) and fermentability can be easily stored and recycled for a possible re-use, as quality feedstock for Anaerobic Digestion systems or for Composting.
- To minimize the labour cost in the food waste management and waste collection and improve the efficiency of the internal organization.
- To be in compliance with HACCP rules.
- To perform a real separate collection of the organic fraction.

Our compact food waste reduction machine is a stainless steel standalone de-watering solution, made up by:

- a hydro extractor, a centrifugal press which separates the liquid from the solid component. The Dehydra dewater apparatus (see fig. 2) is the only self cleaning de-watering system that can be fitted with waste water re-circulation.
- a stainless steel standalone cabinet, which includes a commercial food waste disposer - 2,2 kW, an impeller pump – 0,75 kW and a proper intake hopper.
- an electric control panel equipped with PLC system, which enables the operators to run the unit in safety.

The DEHYDRA SC1 can be placed in the washing area or in cleaning areas of canteens and/or restaurants where it is required to dispose of up to 150 kgs per hour of food waste.

The machine is equipped with a passive safety system, guaranteed by the particular design of the intake hopper which prevents the access to the moving parts of the disposer while in use, and an active safety device which stops the disposer in case of accidental opening of the cabinet's lid. Permanent magnets are installed under the hopper to capture metals avoiding the risk of their accidental falling inside the disposer.

The de-watering unit, placed in the upper side of the DEHYDRA SC1 unit (see fog. 2) is made up by:

- A – a cylinder containing rotating parts (a micro perforated cylindrical screen with a very fine mesh (1,5 mm. diameter holes) and an auger
- B – an engine that ensures the movements to the micro cylindrical sieve and auger
- C – a driving belts and pulleys system to move the screen and the auger at different speed
- D – a inlet flange for the wastewater (a mix of ground food waste and water)
- E – a discharge chute of the dehydrated waste
- F – a draining outlet for the process water



Fig.1

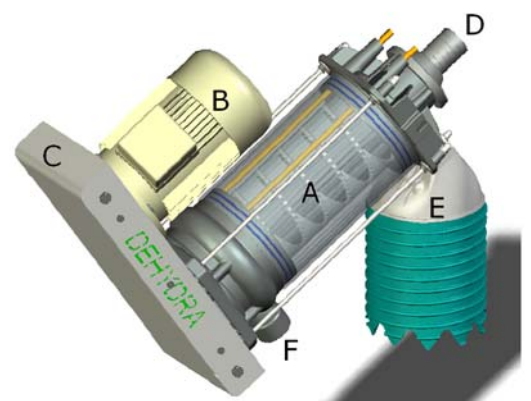

Fig.2

WORKING PRINCIPLE

The machine has been designed to de-water a mixture of food waste, including small bones, ensuring that ground food waste is captured rather than being sent to drain where it may cause blockages and odours.

Food waste is fed into the hopper by the operator and ground into small particles by the food waste disposer (1).

The operation of the whole unit is quick, simple and safe thanks to a design which prevents access to the grinding mechanism while the unit is operating (5).

The ground food waste is then pumped (2) from the disposer into the hydro-extractor (4).

The “hydro-extractor” is the unit that physically makes the de-watering process, separating the liquid from the ground waste: while the watery component can be re-circulated to reduce water consumption before being disposed of to a foul drain into the sewerage system, the organic waste, ground and de-watered, is easily stored into a bin and recycled for a possible re-use.

Once the food waste has been disposed of, the system automatically selfcleans to minimize operator time, thanks to a PLC system control panel (3).

The remaining processed food waste can be used as a highly quality feedstock for Anaerobic Digester system or for Composting.

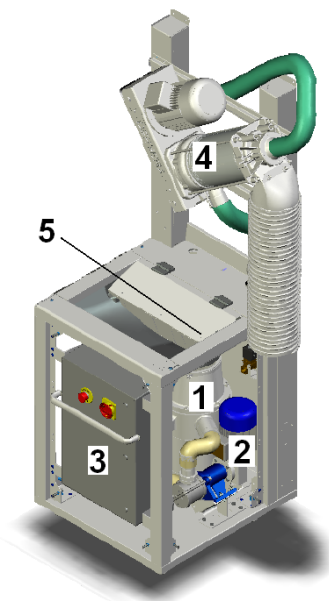

Overall dimension and technical specifications

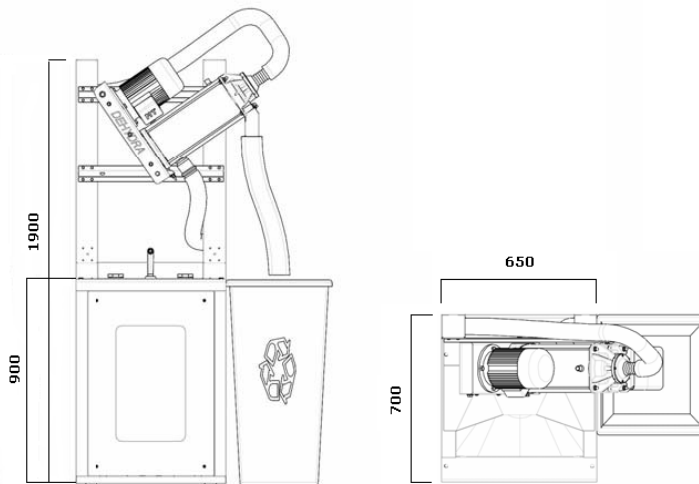

Disposer 2,2 kW – Pump with geared motor 0,75 kW – Hydro-extractor model “DEHYDRA” 1,1 kW

Electrical connection: Power supply : 3 phase 400V – 50Hz **Power input :** 3,9 kw **Socket :** 3P+Earth – 16 Amp (4 wires)

Feed opening dimensions (mm): 530 W x 350 H – **Capacity:** up to 150 kgs per hours / 250 -400 meals per hours

Water connection: cold water : 3/4 o 1/2 - 2.5 bar **hot water :** 3/4 o 1/2 - 2.5 bar – **Water consumption:** Approx. 20 litres per minute

Sewage system connection: 50 mm pipe is required with siphon to avoid odours

Warranty: 1 Year

All the working parts of the unit are in compliance with CE rules, in particular the **DEHYDRA COMPACT STATION SC1** is complying with the following pertinent rules and technical specification:

EC Machine Directive 2006/43/CE

EMC Directive 2004/108/CE – Electromagnetic compatibility directive

Main technical standards applied: **UNI EN ISO 12100-1 - UNI EN ISO 13857 - UNI EN 954-1 - CEI EN 60204-1**